

LINKEO DATA CENTER PDUs

DELIVERING VALUE EACH STEP OF THE WAY



LEGRAND GROUP: A GLOBAL PLAYER

Legrand Group is a global leader. The scope of its offering, its technological expertise, its international presence, and the power of its brands put Legrand in a unique position to deliver value to you and to your customers.

It also sets the Group on a global mission:

#LegrandImprovingLives.

Every day, Legrand stands by the meaning and values of its Group's purpose statement. They are integral to the development of each product and solution. They guide each decision at Legrand. They express its commitment to its customers, to its employees, to its partners, and to society as a whole.

Legrand transforms the spaces where people live, work, and meet. It provides simple, innovative, and sustainable solutions and services. And it tailors them to numerous applications.

New Linkeo Data Center PDUs embody this global approach. And deliver value each step of the way...



ACTIVE
INTERNATIONAL
PRESENCE IN OVER
90 COUNTRIES



SALES IN CLOSE TO
180 COUNTRIES



€6,994 MILLION
IN TOTAL SALES
IN 2021

5% OF TOTAL BUDGET
USED IN R&D



OVER
36,700 EMPLOYEES
WORLDWIDE



RELIABLE, SUSTAINABLE & SCALABLE DATA CENTER SOLUTIONS

With award-winning solutions from strong data center players like Borri, Minkels, Modulan, Raritan, Server Technology, Starline and Zucchini, you benefit from optimal uptime of mission-critical operations. Our team of local specialists design and build innovative solutions including enclosures, cooling, power, structured cabling and access management to meet your unique requirements.

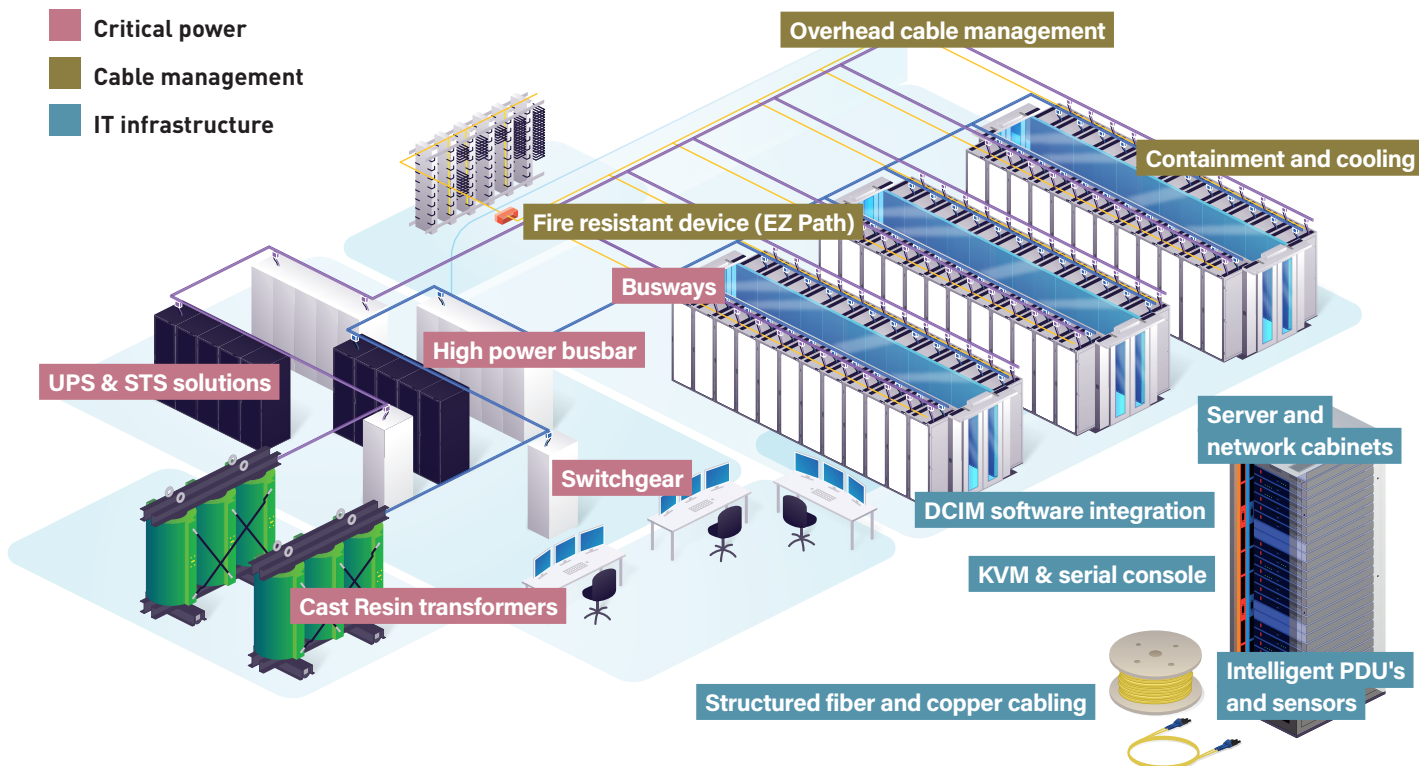

A STRONG COMMITMENT TO GREEN DATA CENTERS

Sustainability has been everybody's challenge for years.

#LegrandImprovingLives means creating **a more sustainable world for everybody.**

It is the Group's ambition to actively contribute to the development of a low-carbon society, in keeping with the RoHS directive (2015/863/UE) and the LEED Green Building Rating System.

In keeping with its CSR guidelines, not only does Legrand work on **reducing its carbon footprint** to fight climate change, but it gives priority to **the development of a circular economy approach**, limiting the quantity of materials used and promoting the reuse of materials. In connection with professional associations BICSI and The Green Grid, it aims to set the standard for energy efficient design.

Every day, Legrand Group takes more steps on the path to green data centers.

As a proof of our circular economy approach, we provide customers with certified environmental declarations (Product Environmental Profiles - PEP).



128 av. du Maréchal-de-Lattre-de-Tassigny
87045 Limoges Cedex France
Tel. +33 (0) 5 55 06 87 87
Fax. +33 (0) 5 55 06 88 88

 Your usual Sales office
www.legrand.com

Product Environmental Profile
Linkeo Data Center Intelligent Metered PDU





ZERO PLASTIC AND BULK PACKAGING

Legrand is determined to phase out single-use plastic, limit waste production, and maximize waste processing. Linkeo Data Center PDUs are delivered without plastic film, facilitating the disposal of used cardboard. To eliminate individual product packaging as much as possible, the Linkeo Data Center offers bulk packaging options with associated minimum order quantities. In this case, PDUs are packaged at pallet level, allowing for up to 86% more units to be shipped on a single pallet. The PDUs are easier to unpack and deploy and you cut down on waste treatment costs.

LOCAL CONFIGURATION CENTERS

Local configuration contributes to Legrand's efforts to achieve its CSR objectives for the reduction of CO₂ emissions. Linkeo Data Center PDUs were designed with efficient and carbon-reduced manufacturing in mind. Units are available from local configuration centers in Europe and Asia. This results in a more efficient lead time with last-mile configuration and delivery to project sites.



HIGH QUALITY AND RELIABILITY

Increasing MTBF is a major stake for data center operators. Hence, Linkeo Data Center PDUs undergo stringent third-party testing and ISO certification under a CB scheme. In the manufacturing process, each PDU is individually tested in order to ensure the highest degree of assembly quality and electrical safety, and the longest operating times within harsh environments.

ENERGY-EFFICIENT DESIGN

In connection with professional associations BICSI and The Green Grid, Legrand aims to set the standard for energy-efficient design. Linkeo Data Center PDUs are manufactured with an internal electrical busbar architecture. This design limits metals and materials applied for PDU assembly and reduces heat within each operating unit. By reducing cooling needs in the white space, it contributes to reducing the environmental footprint of the PDUs. Furthermore, by making it possible to supervise energy supplied to cabinets, and monitor the supply, charge, and status of batteries in real time, the PDUs also significantly contribute to data center energy efficiency.



DELIVERING VALUE EACH STEP OF THE WAY

Legrand Data Center Solutions leverage expertise in white space power from leading brands like Raritan and Server Technology. As a result, Linkeo Data Center PDUs provide extensive features tailored to the needs of the ever-increasing requirements of data centers.

Legrand delivers user value at a competitive cost, facilitating deployment and daily management while improving reliability.

UPTIME

Innovative design with hot swappable, upgradeable elements guarantees optimized uptime.



COST

Smart design and new innovative set-up options contribute to great value for money.



GLOBAL AVAILABILITY

Legrand's manufacturing and logistical power make it possible to deliver standard and Configured To Order PDUs in 15 days*.

*ex-works, depending on quantities







T A B L E O F C O N T E N T S

10

DELIVERING CHOICE

The Linkeo Data Center PDU Line

12

DELIVERING PERFORMANCE

A PDU platform for digital excellence

14

DELIVERING RANGE

Expanding functions from basic to intelligent

16

DELIVERING INNOVATION

An intelligent PDU controller platform

20

DELIVERING ERGONOMY

Easy rack instrumentation, control & monitoring

24

DELIVERING SECURITY

Intelligent PDU firmware management
& cyber security mandate

26

DELIVERING STANDARDS

Linkeo Data Center global industrial model

DELIVERING CHOICE

The Linkeo Data Center PDU Line

From Basic to Switched solutions, this PDU line has been carefully designed to adapt to the diversity of our customers' configurations. Developed on a common platform, it provides solutions that fit your current needs and expectations, while anticipating for maintenance as well as future scaling and upgrades. Depending on your needs, here is an overview of possible configurations:

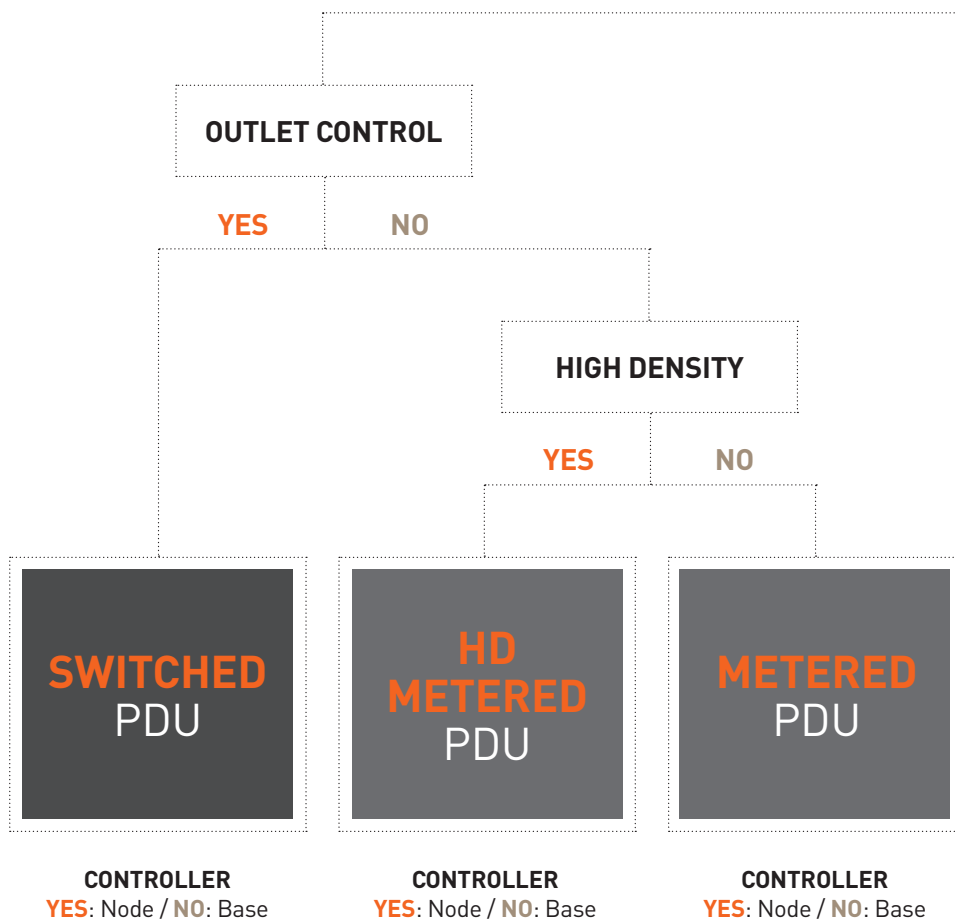

SENSORS

OPTIONS



CONFIGURE TO ORDER: in addition to catalogue references, Linkeo Data Center PDUs offer a large scope

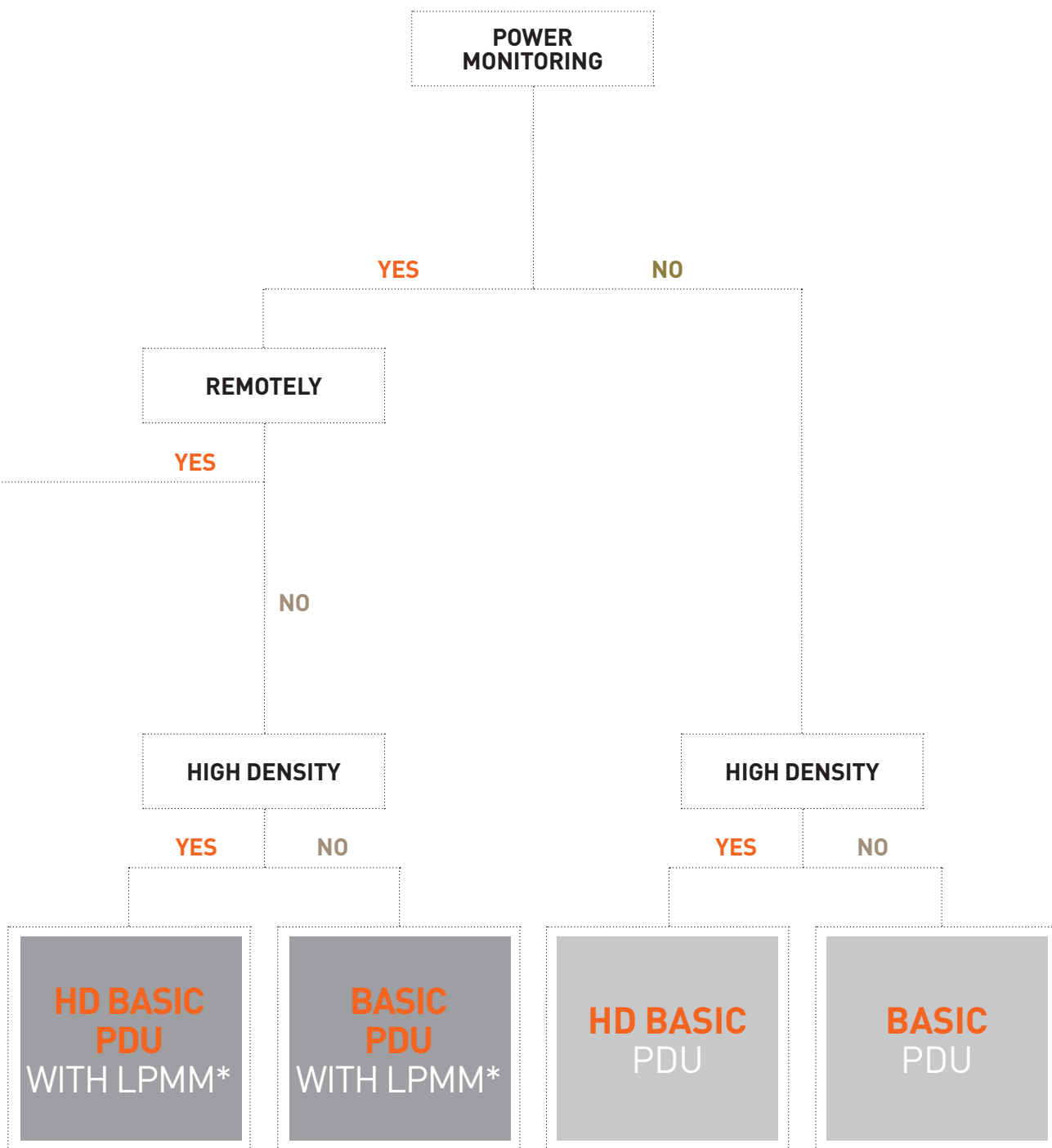

*LPMM = Local Power Meter Module

POWER CORDS

of options to custom form-fit your PDU to your application.

DELIVERING PERFORMANCE

A PDU platform for digital excellence

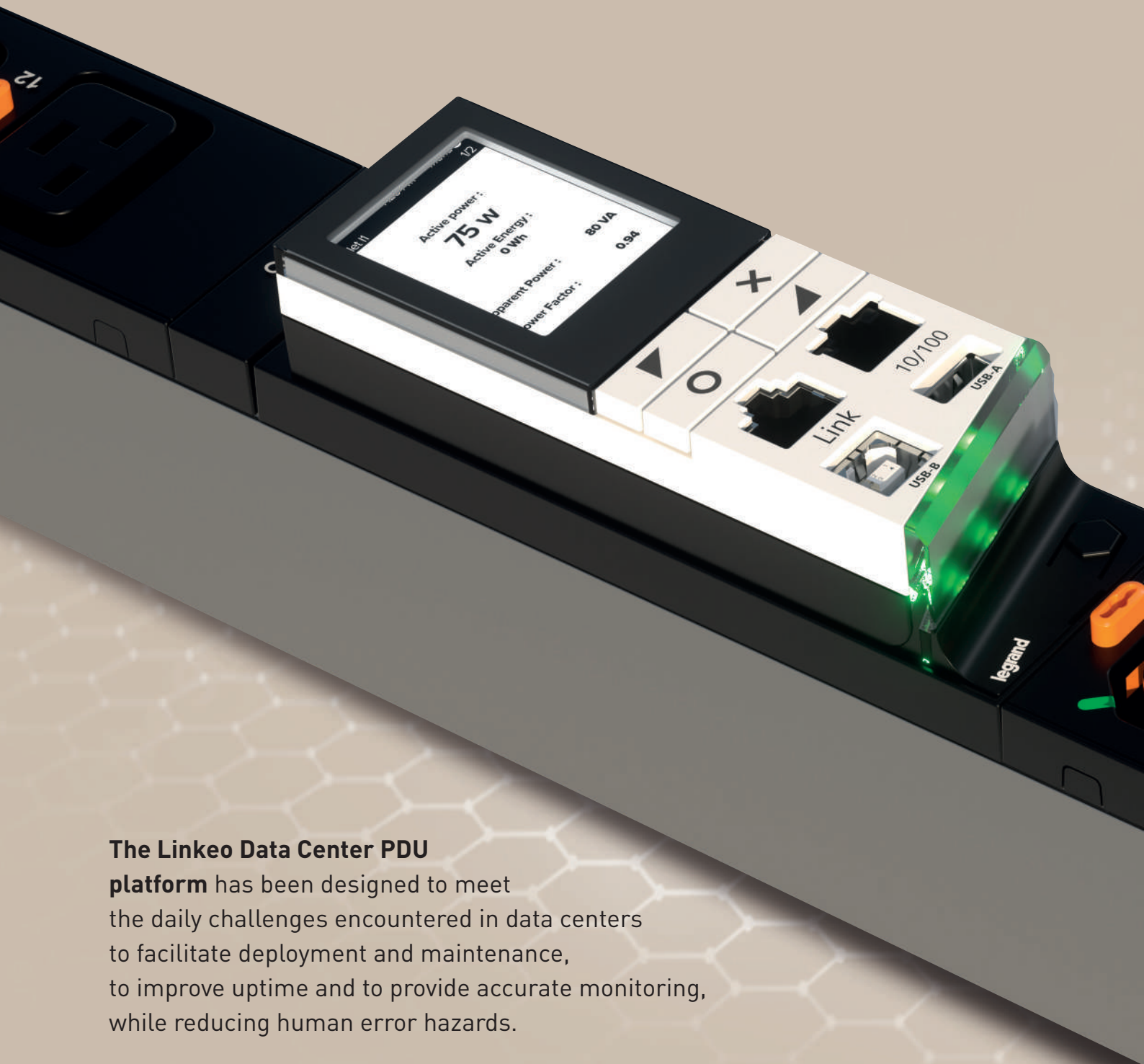

The Linkeo Data Center PDU

platform has been designed to meet the daily challenges encountered in data centers to facilitate deployment and maintenance, to improve uptime and to provide accurate monitoring, while reducing human error hazards.

Providing accurate monitoring

+/-1% accuracy

You can monitor your power data with accurate metering thanks to PDUs LPMM (Local Power Meter Module) or metered/switched PDUs. As a result you have reliable inputs for decision.

Improving uptime

Rating aluminum chassis

The compact aluminum chassis withstands high ambient temperatures.

Hydraulic magnetic circuit protection

The Linkeo Data Center platform offers hydraulic magnetic miniature circuit breakers with high ambient temperature tolerance for tripping, and high interruption capacity.



Facilitating deployment and maintenance



330° rotating input cord

The large rotating range reduces tension on input. It facilitates perfect cable orientation and rack integration.



Hot swappable controller architectures

The metering controller can be removed and replaced without turning down the PDU.



High-density outlet modules

Providing more compact form factors and better airflow in the rack.

Reducing human error



Cord locking system

For absolute safety, our auto-locking outlets provide 100 Newton retention force. No risk of accidental disconnection due to human error or vibration.

This cord locking system is compatible with all standard C14 and C20 plugs. There is no need for specific cords.



Numbered outlets

Individual circuits and power outlets are numbered from the input to facilitate power cord dressing.

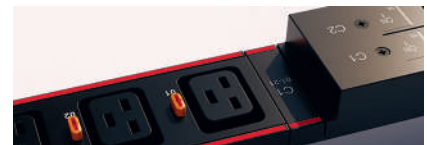

PDU Color-Coding

When extra identification is needed, color-coded circuits and chassis are available on demand.

Power cords with server side locking

Secured on the Legrand PDU side thanks to the standard cord locking system, it is also important to secure the full chain and the server side. Legrand power cords with unique rotary locking mechanisms on C13 and C19 fit any C14 and C20 server inlets.

DELIVERING RANGE

Expanding functions from basic to intelligent

Basic PDU

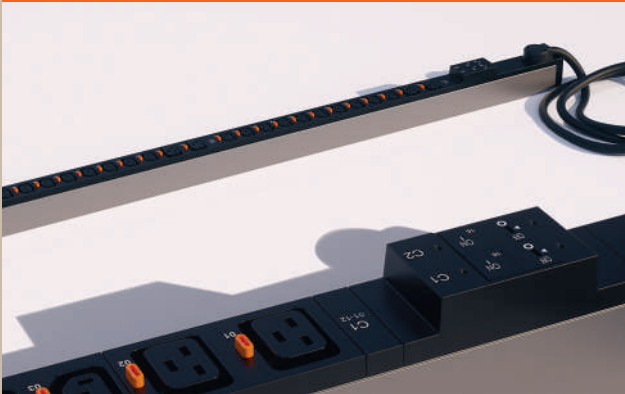

SERVICES PROVIDED

Basic functions

- Reliable power distribution
- Matching configuration of servers
- Protection against overloads (on models equipped with circuit breakers)

Limitations

- If you look for visibility on power capacity and IT loads
→ go for a basic PDU with Local Power Meter or for an intelligent PDU
- If you look for remote management
→ go for an intelligent PDU

KEY FEATURES

- Internal circuitry design against overheating at peak loads
- Hydraulic magnetic circuit protection
- Rating aluminum chassis
- Locking outlet capabilities against accidental disconnects
- Outlet numbering

Basic PDU with local power meter

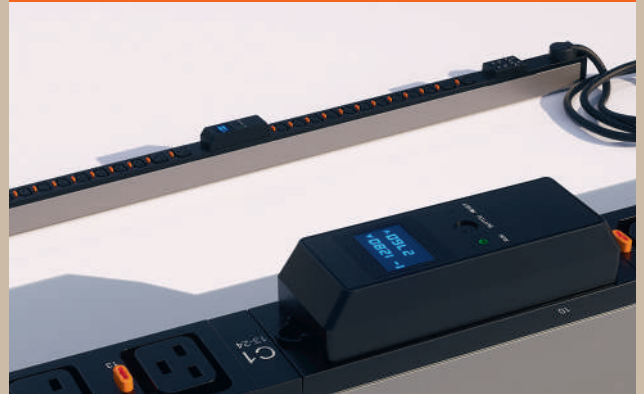

SERVICES PROVIDED

Basic functions

+

LOCAL METERING

- Local measurement of energy consumed at rack level
- Instant visibility on power IT loads
- Instant visibility of available capacity on a given unit
- Screen to read the data locally

Limitations

- If you look for data aggregation or DCIM capability
→ go for an intelligent PDU
- Local technician needed to understand infrastructure behavior at the rack level
- This configuration will not support an upgrade to intelligent PDU

KEY FEATURES

- Visibility of all energy data: Amps, kWh, Volts, Power Factor
- Hot swappable: the metering controller can be removed and replaced without turning down the PDU
- Local alerts if load exceeds 80% of available capacity per line/circuit (beeping)
- Phase, circuits, and branch measurements with +/-1% metering accuracy

Intelligent metered PDU

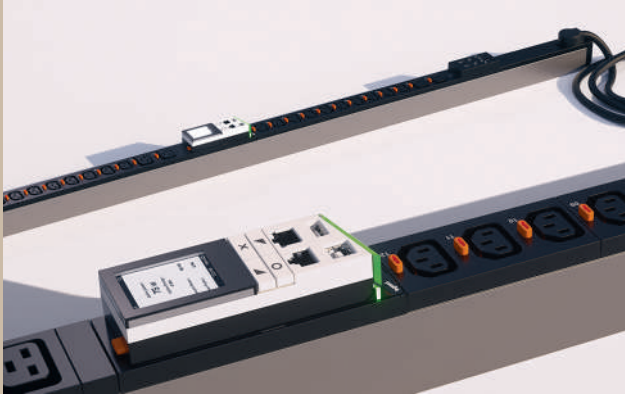

SERVICES PROVIDED

Basic functions

+

Local metering

+

ADVANCED MONITORING

- Remote real-time monitoring on web user interface
- Configurable alerts when a measurement is exceeded
- Aggregation of power metering data at various unit points (inlets, circuits...)
- Data aggregation in DCIM ability

KEY FEATURES

- Cyber security features for seamless integration into the enterprise network architecture
- Cascading features to streamline connectivity
- Hot swappable electronic components in case of failure
- 2 levels of alerts physically visible on the PDU (LED bar) and remotely (web interface and email/sms alert configuration)
- Modular concept: with or without controller

Intelligent switched PDU

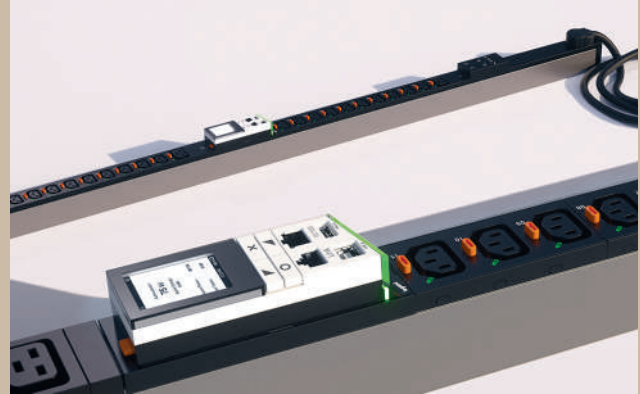

SERVICES PROVIDED

Basic functions

+

Local metering

+

Advanced monitoring

+

SWITCHED MONITORING

- Remote outlet control for power load shedding and IT asset reboot

KEY FEATURES

- Cyber security features for seamless integration into the enterprise network architecture
- Cascading features to streamline connectivity
- Hot swappable electronic components in case of failure
- 2 levels of alerts physically visible on the PDU (LED bar) and remotely (web interface and email/sms alert configuration)
- Modular concept: with or without controller
- LED on each outlet to see the outlet status (on/off)

DELIVERING INNOVATION



An intelligent PDU controller platform

The Linkeo Data Center intelligent PDU is based on a DCIM Agnostic and Open API platform. It is available in a standard Metered and a Switched intelligent version.

Each power configuration can be acquired with only the BASE, or with the NODE, IP controller mounted for extra connectivity. Standard PDU portfolio is available with both BASE-only and BASE+NODE configurations.

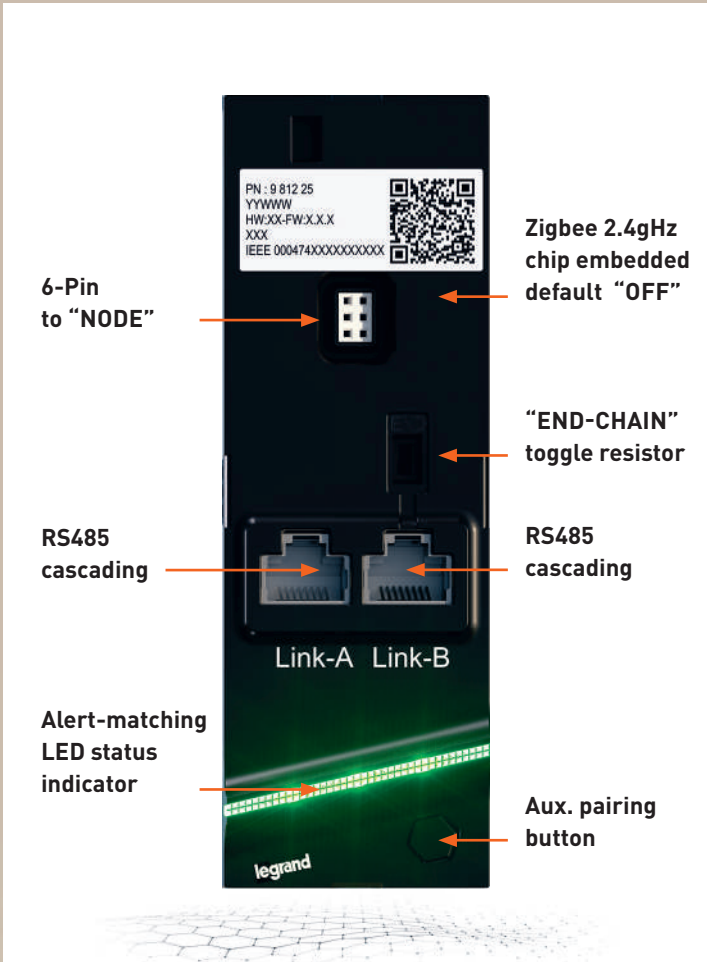

BASE: UPGRADEABLE



- Field replaceable
- Including RS485 industrial bus for linking up to 32 units (data pushed to a Lead NODE unit with RJ45 cable)
- Including RF Chip for Zigbee and green power wireless applications

NODE: HOT SWAPPABLE (W. FIRMWARE)

Robust and full hot swappable IP Controller

- Full IP Controller
- Cybersecurity tested
- Full Hot swappable to allow maintenance or replacement without powering down connected equipment
- NODE IP cascading through USB up to 16 units (full data management)

Zigbee wireless connectivity

Highly secure and power-saving radio frequency technology

- Sensor direct pairing
- Empowering future wireless mesh network deployment
- Providing the highest level of security:
 - Encryption and message integrity with application key exchange
 - Protection against most challenging internet concerns including Distributed Denial-of-Service attacks (DDoS)

Complies with
IMDA Standards DA103632

FLEXIBLE DEPLOYMENT APPLICATIONS

The Linleo Data Center Intelligent PDU allows various deployment methods to accommodate different data center environments and constraints.

To optimize your IT deployments, the most innovative method is the RS485 cascading.

It reduces both your CAPEX, by cutting down the number of IP controllers needed, and your OPEX, by diminishing your production costs (fewer ethernet switch ports).

RS485 MODBUS CASCADING

- Daisy chain up to 31 BASE PDUs downstream to a NODE PDU with RJ 45 patch cables (RS 485 - link)
- Only the NODE PDU is connected to your network
- NODE controller aggregates all BASE units data into its user interface. Thresholds and alerts are configured directly in the NODE unit
- Reduce CAPEX and deploy intelligent PDUs without the need to have a PDU controller in every unit
- Reduce your OPEX, using less ethernet switch ports

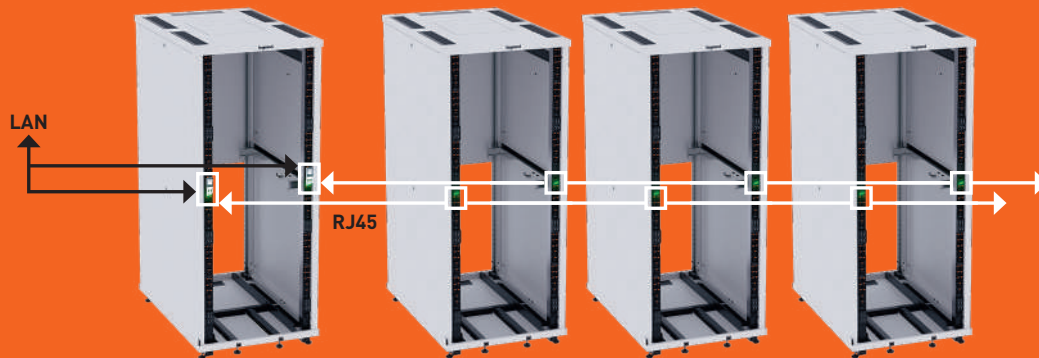

Deployment illustration with one daisy chain on feed A and one daisy chain on feed B

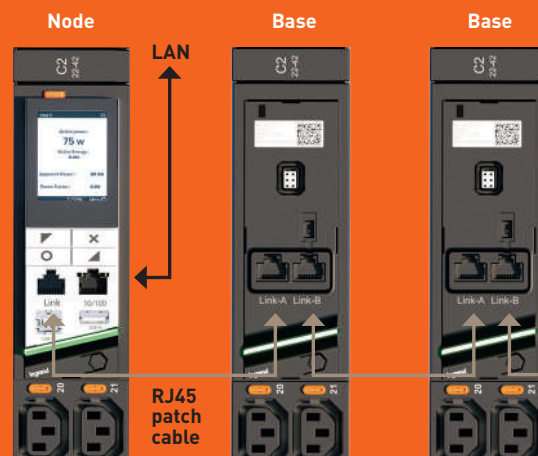

USB CASCADING

- Daisy chain up to 16 NODE PDUs using their respective USB ports
- Only the NODE PDU at the head of your daisy chain is connected to your network
- Have one IP address for the daisy chain with a "port forwarding" method or a one IP address for each PDU with a "bridging" method
- Reduce your OPEX, using fewer ethernet switch ports

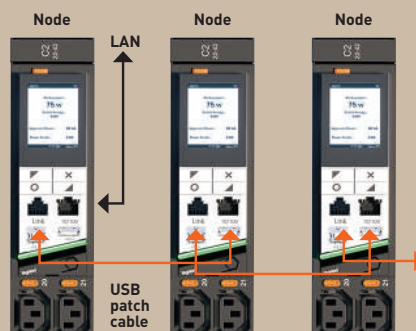
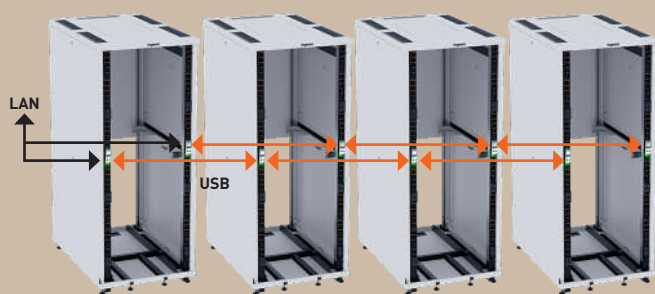

STANDALONE

- Use only NODE PDUs
- Each NODE PDU is connected to your network

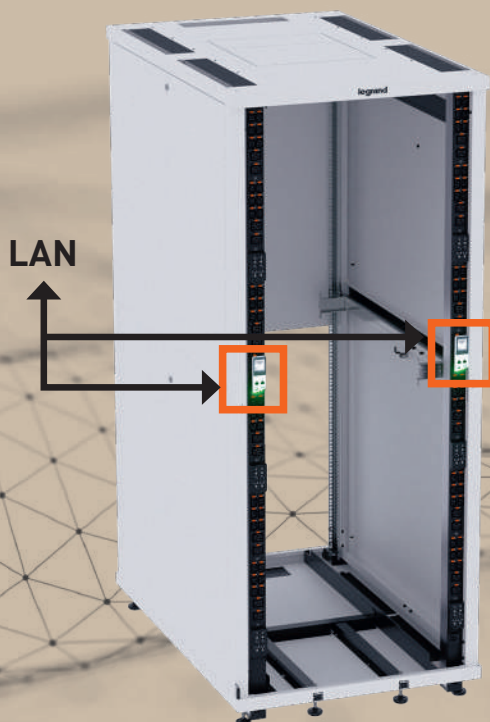

DELIVERING ERGONOMY

Easy rack instrumentation, control & monitoring

The **Linkeo Data Center Intelligent PDU** has been designed to provide you with the best experience, from installation to effective data measuring and management.

WIRELESS SENSORS TO MONITOR ENVIRONMENTAL RISKS

Our **wireless sensors** are easy to fix in your racks, collecting data on environmental risk factors that have an impact on uptime, performance and cost.



Protection against environmental risks and human error



Easy detection of hot spots and risky environmental conditions



5-year minimum battery life on all sensors with replaceable batteries



Secure and reliable installation



Highly accurate environment monitoring (+/- 1% temperature/humidity accuracy)



Reduction of cooling costs and optimization of rack airflow delivery



Easy wire-free deployment and maintenance, with various fixing methods possible



Energy-friendly radio communications powered by Zigbee Green PowerTechnology



SENSORS

- Pair up to 8 sensors per PDU, whether it is a Node PDU or a Base PDU
- Zigbee technology natively embedded in Node and Base PDUs



TEMPERATURE & HUMIDITY

Temperature & Humidity Wireless Sensor

Monitors rack airflow delivery to optimize cooling infrastructure, prevent equipment damage and reduce energy cost.

DOOR OPEN & CLOSE

Contact Closure Wireless Sensor

Manages door contact and alerts in case of door opening/closing; tracks work orders to identify human error.

» MAIN BENEFIT

Wire-free deployment = ease and cost savings

- Reduce sensor deployment time and maintenance
- Easily move sensors from rack to rack

METERING AND SWITCHING TO CONTROL YOUR POWER

Advanced monitoring with accuracy

Preventing outages in your data center starts with ensuring access to reliable and accurate monitoring data. Linkeo Data Center intelligent PDUs have +/- 1% measurement accuracy with all types of loads, in real time. You can rely on your PDUs supplying the required information as and when needed.

Metered intelligent PDUs for consumption monitoring

Our Metered iPDUs incorporate input metering, which allows for accurate measurement of the unit's energy consumption. They make it easy to understand power and manage your data center growth.

Easier data collection in the cabinet

- No need for technical teams to take on-site measurements
- Easy access to equipment energy consumption

Unit power overview

- Gives an overview of rack power capacity and energy use
- Clearly shows remaining capacity in the cabinet
- Provides insight regarding decisions about future growth

Switched intelligent PDUs for easier power management

Our Switched iPDUs integrate **input metering and output level switching**, providing granular power switching of each device connected to the iPDU, thus **improving availability**.

It makes it easier to **manage multiple facilities remotely**, contributing to avoid financial and environmental costs associated with travel to sites.

Remote outlet management

- Prevents human errors
- Prevents overloads by checking that devices are only plugged in on available circuits

Output control

- Configurable outlet rebooting schedule
- Avoided power waste by scheduling power loads
- Remote hard-reboot

Your situation at a glance

User-friendly and responsive Web User Interface

- Metering, outlet control and peripherals data at glance
- Easy to configure
- No-fuss peripheral commissioning
- Dynamic HTML to support multi devices

Configurable alerts

4 thresholds per parameter:

- Measurement: above or below
- Priority: high or low

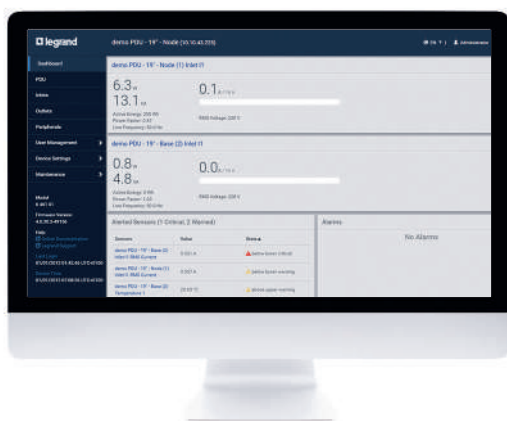

Metering, outlet control and peripherals data at glance

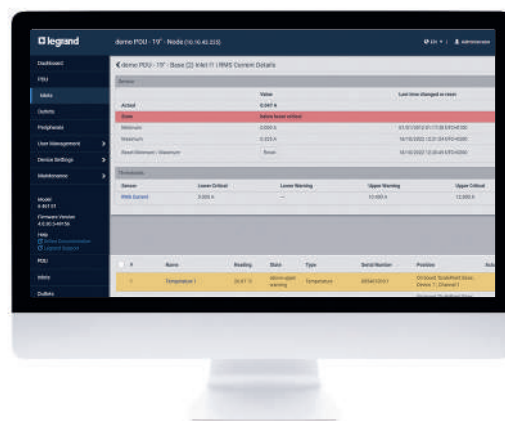

See alerts on Web UI and set up alert sending (e.g. emails)



See alerts on the PDU for field technicians

DELIVERING SECURITY

Intelligent PDU firmware management & cyber security mandate

The platform used for Linkeo Data Center PDUs is a combination of hardware and software technologies benefiting from Raritan's long experience. It helps to maximize data center efficiency by delivering security, advanced alerting, intelligence, and visibility into your power chain. Best-in-class in cybersecurity, it has been tested internally and by third party according to stringent compliance audit.

UNIFYING SYSTEM FOR MORE INTELLIGENCE

The platform provides complete visibility to your power chain, making it easier to connect, configure, and manage your data center.

- Firmware designed and maintained in-house for complete control
- Interoperable, open architecture for quickly future proofing application development

DELIVER UNPARALLELED SECURITY

The platform delivers improved security across your data facility with the latest network security protocols, best-in-class data encryption, strong password policies, and login protection.

- Deploy a power infrastructure that matches your enterprise network and IT security requirements
- Ensure secured and encrypted communications
- Control user access and safeguard against errors and malicious intents

256-BIT
AES
ENCRYPTION

SSH
(SECURE
SHELL)

SSL
TO TLS 1.3

HTTPS

SIMPLIFY YOUR PATH TO DCIM

The platform is built on a developer friendly platform which allows for easy automation and seamless transfer of infrastructure insights and alerts directly to BMS and DCIM software.

- Seamlessly discover, import, manage, and control your Linkeo Data Center devices in Energy Management Software
- Develop more automation and efficient alerting to help improve data center operations

REDFISH

SNMP
AND SNMP
TRAPS

IPV6/IPV4
SUPPORT

JSON-RPC,
MODBUS
TCP

BUILD A FUTURE-PROOF INFRASTRUCTURE

It brings reliability to the forefront by focusing on continuous uptime for your data center with battletested hardware and firmware with billions of hours of runtime.

- Continuous firmware development to enrich your existing hardware deployment
- Field-based innovation from customer feedback to deliver relevant applications and support your business growth with a future-proof solution

OUR PLATFORM

USER INTERFACE/API

Responsive HTML GUI

APPLICATIONS

Environmental Monitoring, User Access Monitoring, Rule Based Alerting,
Asset Management, Power and Energy Management

NETWORK SECURITY

Certificates, Firewall, DDOS Attack Protection,
Strong Configurable Passwords, Enterprise Authentication

OPERATING SYSTEM

Proprietary Firmware Design, Hardened Linux CentOS, IoT Enabled

CONTROLLER

Base and Hot Swappable Node

HARDWARE

In-house Mechanical, Electrical and PCBA Design.
Best-in-class Testing and Assembly. Perfect Fit to Any Rack Environment

DELIVERING STANDARDS

Linkeo Data Center global industrial model

The Linkeo Data Center PDU platform meets your power distribution needs worldwide. Four types are available: Basic, Basic with Local Metering, Intelligent Metered and Intelligent Switched. Regardless of geographical area, all delivery models are consistent, and physical specifications comply with IEC standards.

The Linkeo Data Center PDU helps you create standards for your global deployments in the Europe, Middle East, Africa, Asia Pacific and Latin America.

LOCAL CONFIGURATION CENTERS

Local configuration contributes to Legrand's efforts to achieve its CSR for the reduction of CO₂ emissions. Linkeo Data Center PDUs were designed with efficient, and carbon-reduced manufacturing in mind. Units are available from local configuration centers in Europe and Asia. This results in a more efficient lead time with last-mile configuration and delivery to project sites with the same quality standards.

PROVIDING FAST CONFIGURATION TO ORDER

Only 15-day lead time

The platform is available everywhere to make sure your deployment is not delayed.

A large scope of options

Custom form-fit your PDU to your application: input cord types and lengths, circuit protection, surge protection options, outlet types and densities...

Outlet types

Circuit protection types

Form factor 0U, 1U, LD, HD



Numbering & color coding per phase, per unit

Circuit options: power indicator, surge...

Input type, cord lengths

LEGRAND **SUPPORTS YOU**

With its worldwide reach, and particularly its local sales and tech support teams from Legrand Data Center Solutions, Legrand is here to help you in your data center design and deployment with integrated solutions. Linkeo Data Center PDUs have integration capabilities in Group rack offerings (Linkeo Data Center racks, Nexpan racks, ...)

Power Distribution Units (PDU), Linleo Data Center

Basic and Basic with Local Power Meter



To provide ~ electric power for IT equipment in 19" enclosures
 Equipped with hydraulic magnetic circuit protection with high current interruption capacity. Hydraulic magnetic circuit breakers are not affected by ambient temperature
 330° rotating cable input for a perfect orientation of the cable and no interference in the cabinet
 IEC 60320 C13 and C19 outlets. Each C13 and C19 outlets are numbered gradually from the input and equipped with cord locking system to avoid any accidental disconnection (100 Newton retention force).
 High Density (HD) PDUs provide a high density of C13 outlets to optimize outlet quantity and PDU length.
 High ambient temperature rating
 Aluminium chassis
 Zero-U PDUs for vertical mounting in the cabinet. Supplied with standard and button-type mounting brackets.

Pack	Cat.Nos	Basic PDU
1	6 469 60	Single phase - 16 A 230 V - 50/60 Hz power supply 18 C13 outlets + 6 C19 3 m power supply cord with IEC 60309 16A plug
1	6 469 61	20 C13 outlets + 4 C19 C20 inlet (can receive power cables Cat.No 6 469 05 and 6 469 06)
1	6 469 62	Single phase - 32 A 230 V - 50/60 Hz power supply 20 C13 outlets + 4 C19 3 m power supply cord with IEC 60309 32A plug
1	6 469 63	12 C13 outlets + 12 C19 3 m power supply cord with IEC 60309 32A plug
1	6 469 64	Three phase - 16 A 400 V - 50/60 Hz power supply 21 C13 outlets + 3 C19 3 m power supply cord with IEC 60309 16A plug
1	6 469 65	24 C13 outlets + 6 C19 3 m power supply cord with IEC 60309 16A plug

Pack	Cat.Nos	Basic PDU with Local Power Meter
1	6 469 66	Local Power Meter module monitors voltage (V), current (A), active power (kW) and energy (kWh) Phase and circuits measurements: +/- 1% metering accuracy Data's display on SLCD screen Buzzer alarm Hot swappable architecture Single phase - 32A 230 V - 50/60 Hz power supply 20 C13 outlets + 4 C19 3 m power supply cord with IEC 60309 32A plug

Pack	Cat.Nos	Basic HD PDU
1	6 469 71	Single phase - 32 A 230 V - 50/60 Hz power supply 24 C13 outlets + 12 C19 3 m power supply cord with IEC 60309 32A plug
1	6 469 72	36 C13 outlets + 6 C19 3 m power supply cord with IEC 60309 32A plug
1	6 469 11	Three phase - 16 A 400 V - 50/60 Hz power supply 24 C13 outlets + 12 C19 3 m power supply cord with IEC 60309 16A plug
1	6 469 10	36 C13 outlets + 6 C19 3 m power supply cord with IEC 60309 16A plug
1	6 469 73	Three phase - 32 A 400 V - 50/60 Hz power supply 24 C13 outlets + 12 C19 3 m power supply cord with IEC 60309 32A plug
1	6 469 74	36 C13 outlets + 12 C19 3 m power supply cord with IEC 60309 32A plug
1	6 469 75	36 C13 outlets + 6 C19 3 m power supply cord with IEC 60309 32A plug

Pack	Cat.Nos	Basic HD PDU with Local Power Meter
1	6 469 70	Local Power Meter module monitors voltage (V), current (A), active power (kW) and energy (kWh) Phase and circuits measurements: +/- 1% metering accuracy Data's display on SLCD screen Buzzer alarm Hot swappable architecture Three phase - 16 A 400 V - 50/60 Hz power supply 36 C13 outlets + 6 C19 3 m power supply cord with IEC 60309 16A plug

Configure To Order: Need another configuration and/or functions ? Legrand is organized to configure PDUs as per your request. Please contact your sales representative

Power Distribution Units (PDU), Lincoo Data Center

Intelligent Metered, Intelligent Switched

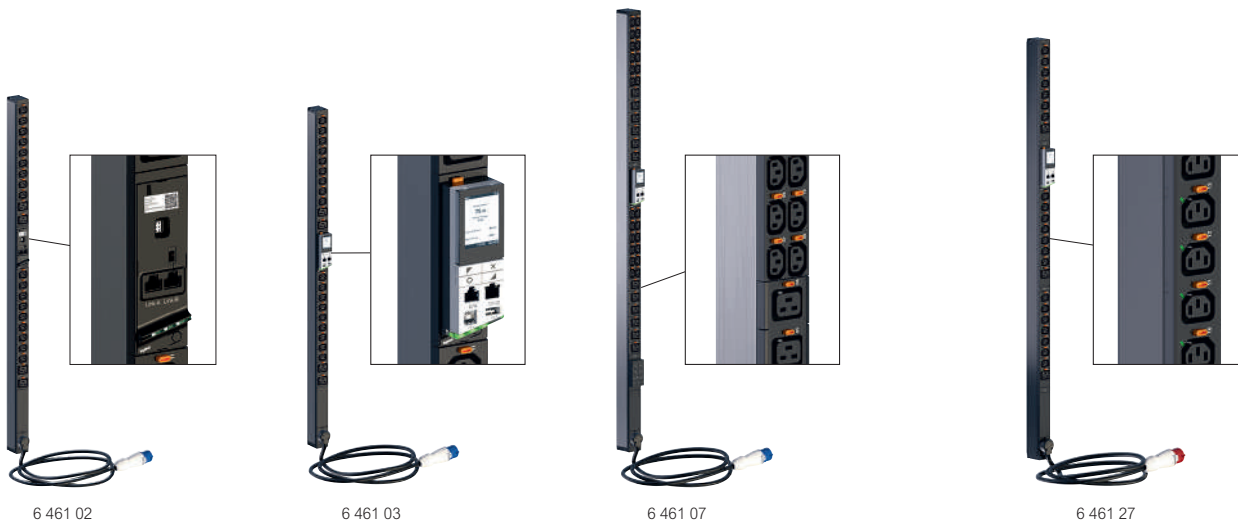

To provide ~ electric power for IT equipment in 19" enclosures

Metering at inlet level (+/- 1% metering accuracy)

Connected device enabling remote access to all measurements and alerts

2 versions available: NODE version with all functions and BASE version

NODE PDU: with hot swappable full IP controller for connection to LAN. Possible cascading of up to 16 node PDUs with USB cords

BASE PDU: without controller. Need to be connected to a NODE PDU for IP connection. Possible cascading of up to 31 base PDUs downstream to a node PDU with RJ 45 patch cables (RS 485 - Modbus link). BASE is hot swappable and upgradable with a node controller Cat.No 6 461 30

Possibility to add wireless sensors (temperature, humidity...) for environmental monitoring

Equipped with hydraulic magnetic circuit protection with high current interruption capacity. Hydraulic magnetic circuit breakers are not affected by ambient temperature

330° rotating cable input for a perfect orientation of the cable and no interference in the cabinet

IEC 60320 C13 and C19 outlets. Each C13 and C19 outlets are numbered gradually from the input and equipped with cord locking system to avoid any accidental disconnection (100 Newton retention force).

High Density (HD) PDUs provide a high density of C13 outlets to optimize outlets quantities and PDU length.

High ambient temperature rating

Aluminium chassis.

19" PDUs and Zero-U PDUs for vertical mounting in the cabinet (supplied with standard and button-type mounting brackets).

Pack	Cat.Nos		Intelligent metered PDUs
1	Base version 6 461 00	Node version 6 461 01	Single phase - 16 A 230 V - 50/60 Hz power supply 8 C13 outlets 19" PDU
1	6 461 02	6 461 03	C20 inlet (can receive power cables Cat.No 6 469 05 and 6 469 06) 18 C13 outlets + 4 C19 3 m power supply cord with IEC 60309 16 A plug
1	6 461 04	6 461 05	Single phase - 32 A 230 V - 50/60 Hz power supply 20 C13 outlets + 4 C19 3 m power supply cord with IEC 60309 32 A plug
			Intelligent metered HD PDUs
1	Base version 6 461 06	Node version 6 461 07	Single phase - 32 A 230 V - 50/60 Hz power supply 3 m power supply cord with IEC 60309 32 A plug
1	6 461 08	6 461 09	24 C13 outlets - 12 C19 36 C13 outlets + 6 C19
1	6 461 10	6 461 11	Three phase - 16 A 400 V - 50/60 Hz power supply 3 m power supply cord with IEC 60309 16 A plug 36 C13 outlets + 6 C19
1	6 461 12	6 461 13	Three phase - 32 A 400 V - 50/60 Hz power supply 3 m power supply cord with IEC 60309 32 A plug
1	6 461 14	6 461 15	24 C13 outlets + 12 C19
1	6 461 16	6 461 17	36 C13 outlets + 12 C19 36 C13 outlets + 6 C19

Pack	Cat.Nos		Intelligent switched PDUs
1	Base version 6 461 20	Node version 6 461 21	Outlets switching. Remotely on/off control of each outlet Single phase - 16 A 230 V - 50/60 Hz power supply 21 C13 outlets - 3 C19 C20 inlet (can receive power cables Cat.No 6 469 05 and 6 469 06)
1	6 461 22	6 461 23	Single phase - 32 A 230 V - 50/60 Hz power supply 20 C13 outlets + 2 C19 3 m power supply cord with IEC 60309 32 A plug
1	6 461 24	6 461 25	21 C13 outlets + 3 C19 3 m power supply cord with IEC 60309 32 A plug
1	6 461 26	6 461 27	Three phase - 16 A 400 V - 50/60 Hz power supply 21 C13 outlets - 3 C19 3 m power supply cord with IEC 60309 32 A plug
1	6 461 28	6 461 29	24 C13 outlets + 6 C19 3 m power supply cord with IEC 60309 32 A plug



Configure To Order: Need another configuration and/or functions ? Legrand is organized to configure PDUs as per your request. Please contact your sales representative

Power Distribution Units (PDU), Linleo Data Center

accessories and Power cords



6 461 30



6 460 03



6 441 01



6 442 07

Pack	Cat.Nos	Accessories for metered and switched Intelligent PDUs
1	6 461 30	Node PDU controller Controller module Plug the controller on a base version of intelligent PDU to transform it into a node version Wireless sensors For cabinet environmental monitoring Easy wire-free deployment and maintenance Wireless communication with PDUs (2.4 GHz Zigbee Green Power) Ultra long battery life (5+ years replaceable battery) Different fixing solutions for sensors: with double sided tape, with cable ties, with a swing nut (supplied with the sensors) or with accessory Cat.No 6 460 06 for a more stylish installation
1	6 460 03	Temperature & Humidity wireless sensor Monitors cool air entering and/or hot air being expelled, and optimizes your cooling infrastructure
1	6 460 04	Contact closure wireless sensor To be installed inside the rack to manage door contact sensors and alert in case of door opening/ closing

Pack	Cat.Nos	Accessories for all PDUs
1	6 469 05	Power cables Cable IEC 60320 C19 to IEC 60309 16A 2P+E plug Rotary locking mechanism on C19 plug that fits any standard C20 inlet to avoid accidental disconnection
1	6 469 06	
1	9 812 27	Brackets 1 set of Zero-U PDU mounting bracket for Nexpan rack
1	9 812 28	10 sets of Zero-U PDU mounting bracket for Nexpan rack
6	6 468 94	Locking caps To block the use of an outlet. A key is necessary to remove the cap and free the access Light grey RAL 7035
6	6 468 95	

Pack	Cat.Nos	Power cords C14 to C13 plugs
		Server side locking Unique rotary mechanism on C13 plug that fits any standard C14 inlet Set of 10
1	6 441 00	Black Length 0.5 m
1	6 441 01	Length 1 m
1	6 441 02	Length 1.5 m
1	6 441 03	Length 2 m
1	6 441 06	Red Length 0.5 m
1	6 441 07	Length 1 m
1	6 441 08	Length 1.5 m
1	6 441 09	Length 2 m
1	6 441 12	Blue Length 0.5 m
1	6 441 13	Length 1 m
1	6 441 14	Length 1.5 m
1	6 441 15	Length 2 m

Pack	Cat.Nos	Power cords C20 to C19 plugs
		Server side locking Unique rotary mechanism on C19 plug that fits any standard C20 inlet Set of 10
1	6 442 01	Black Length 1 m
1	6 442 02	Length 1,5 m
1	6 442 03	Length 2 m
1	6 442 07	Red Length 1 m
1	6 442 08	Length 1,5 m
1	6 442 09	Length 2 m
1	6 442 13	Blue Length 1 m
1	6 442 14	Length 1,5 m
1	6 442 15	Length 2 m

Notes

A series of horizontal dotted lines for writing notes, spanning the width of the page.



Legrand (S) Pte Ltd

17 Neythal Road,

Singapore 628582

Tel: + 65 6416 1550

Fax: + 65 6416 1580

Email: customerhub.sg@legrand.com.sg

legrand.com.sg

youtube.com/user/legrand

facebook.com/LegrandSingapore

linkedin.com/company/legrand-s-pte-ltd

pinterest.com/legrandgroup

instagram.com/legrandnews